

Autodesk®
Moldflow® Insight

Plastics made perfect.

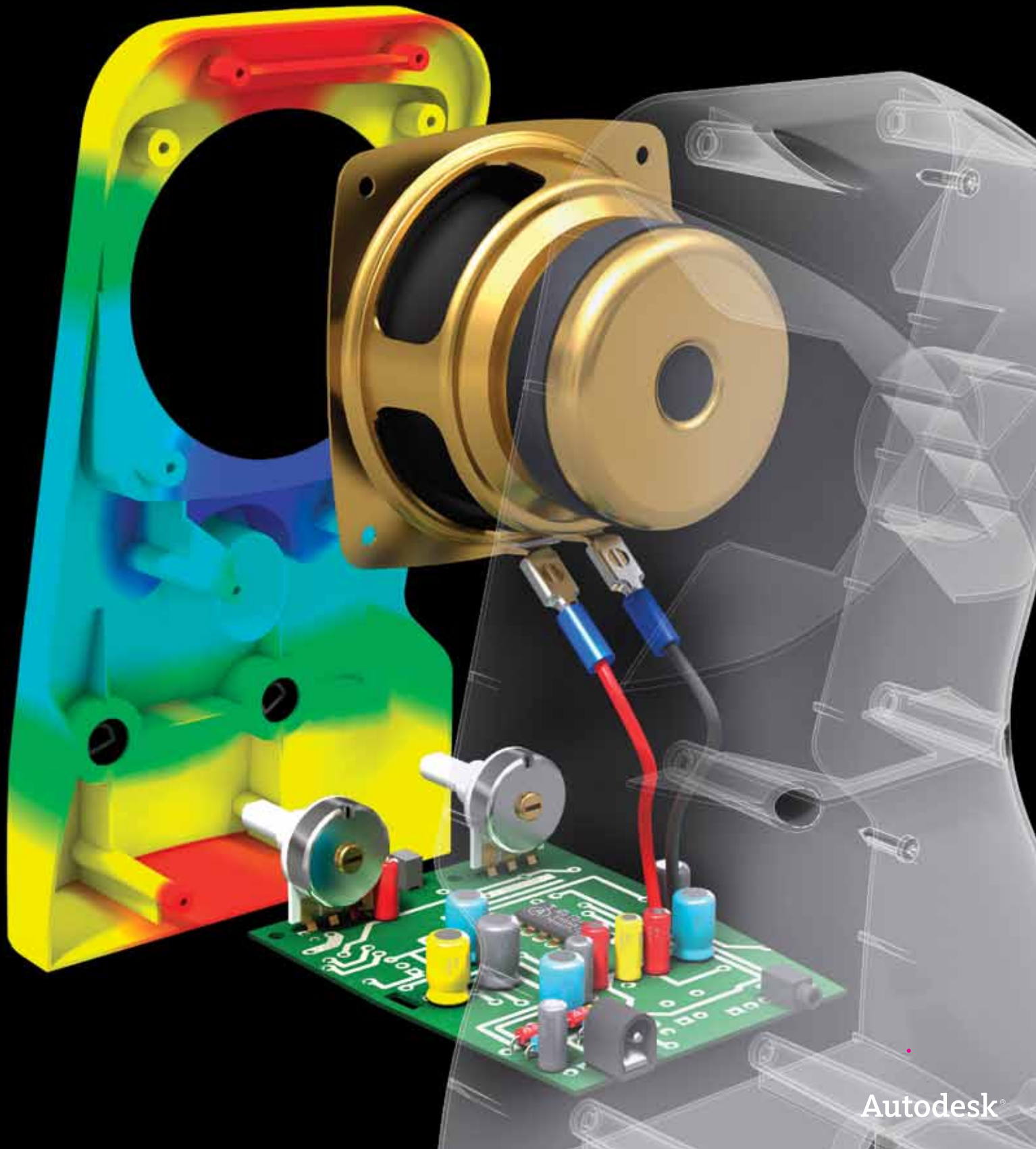

Autodesk®

Validation and Optimization of Plastic Parts

With the use of plastic parts on the rise in almost every industry, and the pressure to reduce costs and cut time to market, the need for simulation tools that provide deep insight into the plastic injection molding process has never been greater.

Contents

| | |
|--|---|
| Validation and Optimization of Plastic Parts | 1 |
| Simulation..... | 2 |
| CAD Interoperability and Meshing | 5 |
| Results Evaluation and Productivity Tools..... | 6 |

Autodesk® Moldflow® Insight software, part of the Autodesk® solution for Digital Prototyping, provides injection molding simulation tools for use on digital prototypes. Providing in-depth validation and optimization of plastic parts and associated injection molds, Autodesk Moldflow Insight software helps study the injection molding processes in use today. Used by some of the top manufacturers in the automotive, consumer electronics, medical, and packaging industries, Autodesk Moldflow Insight software helps to reduce the need for costly mold rework and physical prototypes, minimize delays associated with removing molds from production, and get innovative products to market faster.

Autodesk Moldflow Insight Product Line

Autodesk is dedicated to providing a wide range of injection molding simulation tools to help CAE analysts, designers, engineers, mold makers, and molding professionals create accurate digital prototypes and bring better products to market at less cost.

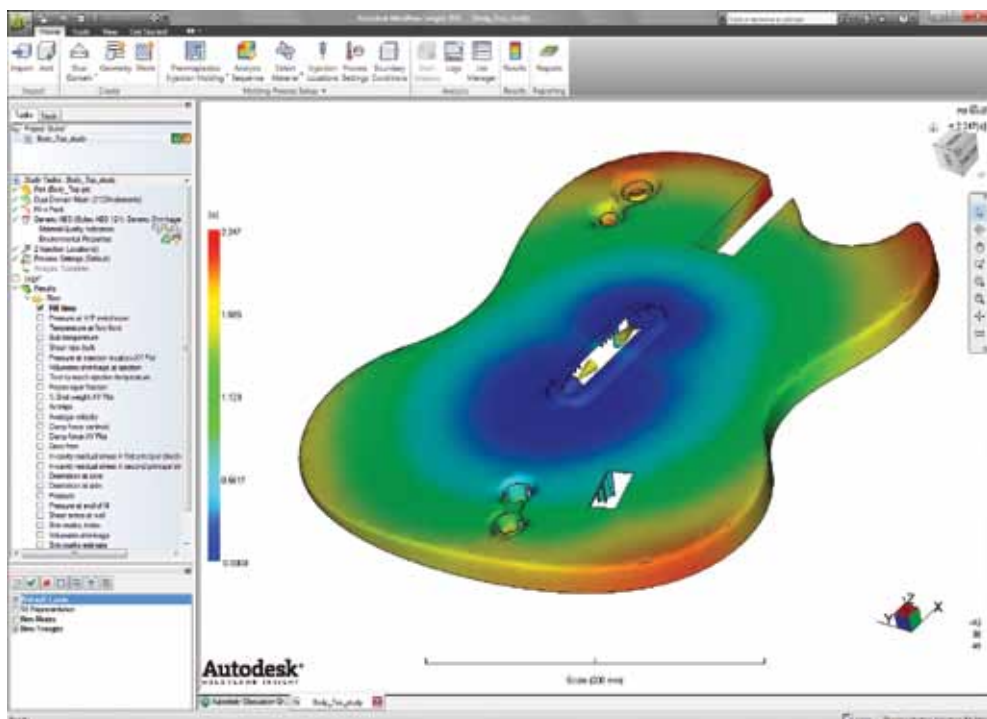

Simulation

Validate and optimize plastic parts, injection molds, and the injection molding process.

Plastic Flow Simulation

Simulate the flow of melted plastic to help optimize part and mold designs, reduce potential part defects, and improve the molding process.

Part Defects

Determine potential part defects, such as weld lines, air traps, and sink marks, and then rework designs to help avoid these problems.

Thermoplastic Filling

Simulate the filling phase of the thermoplastic injection molding process to help predict the flow of melted plastic and fill mold cavities uniformly; avoid short shots; and eliminate, minimize, or reposition weld lines and air traps.

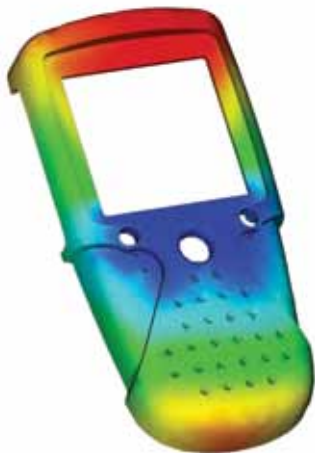

Thermoplastic Packing

Optimize packing profiles and visualize magnitude and distribution of volumetric shrinkage to help minimize part warpage and reduce defects, such as sink marks.

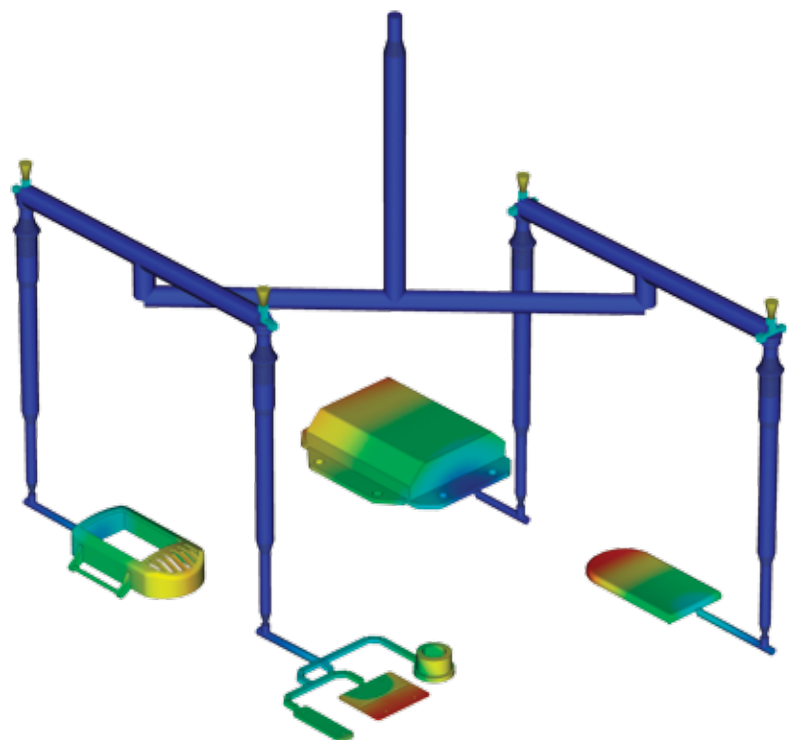

Feed System Simulation

Model and optimize hot and cold runner systems and gating configurations. Improve part surfaces, minimize part warpage, and reduce cycle times.

Gate Location

Identify up to 10 gate locations simultaneously. Minimize injection pressure and exclude specific areas when determining gate location.

Runner Design Wizard

Create feed systems based on inputs for layout, size, and type of components, such as sprue, runners, and gates.

Balancing Runners

Balance runner systems of single-cavity, multicavity, and family mold layouts so parts fill simultaneously, reducing stress levels and volume of material.

Hot Runner Systems

Model hot runner system components and set up sequential valve gates to help eliminate weld lines and control the packing phase.



Simulation

Mold Cooling Simulation

Improve cooling system efficiency, minimize part warpage, achieve smooth surfaces, and reduce cycle times.

Cooling Component Modeling

Analyze the mold's cooling system efficiency. Model cooling circuits, baffles, bubblers, and mold inserts and bases.

Cooling System Analysis

Optimize mold and cooling circuit designs to help achieve uniform part cooling, minimize cycle times, reduce part warpage, and decrease manufacturing costs.

Rapid Heat Cycle Molding

Set up variable mold surface temperature profiles to both maintain warmer temperatures during filling to achieve smooth surfaces, and also reduce temperatures in the packing and cooling phases to help freeze parts and decrease cycle times.

Shrinkage & Warpage Simulation

Evaluate part and mold designs to help control shrinkage and warpage.

Shrinkage

Meet part tolerances by predicting part shrinkage based on processing parameters and grade-specific material data.

Warpage

Predict warpage resulting from process-induced stresses. Identify where warpage might occur and optimize part and mold design, material choice, and processing parameters to help control part deformation.

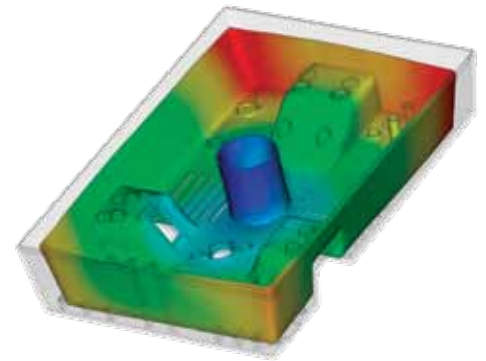

Core Shift Control

Minimize the movement of mold cores by determining ideal processing conditions for injection pressure, packing profile, and gate locations.

Fiber Orientation

Control fiber orientation within plastics to help reduce part shrinkage and warpage across the molded part.

CAE Data Exchange

Validate and optimize plastic part designs using tools to exchange data with structural simulation software. CAE data exchange is available with Autodesk® Algor® Simulation, ANSYS®, and Abaqus® structural simulation software to account for the effects of processing on the performance of fiber-filled, injection-molded plastic parts when subjected to service loading.

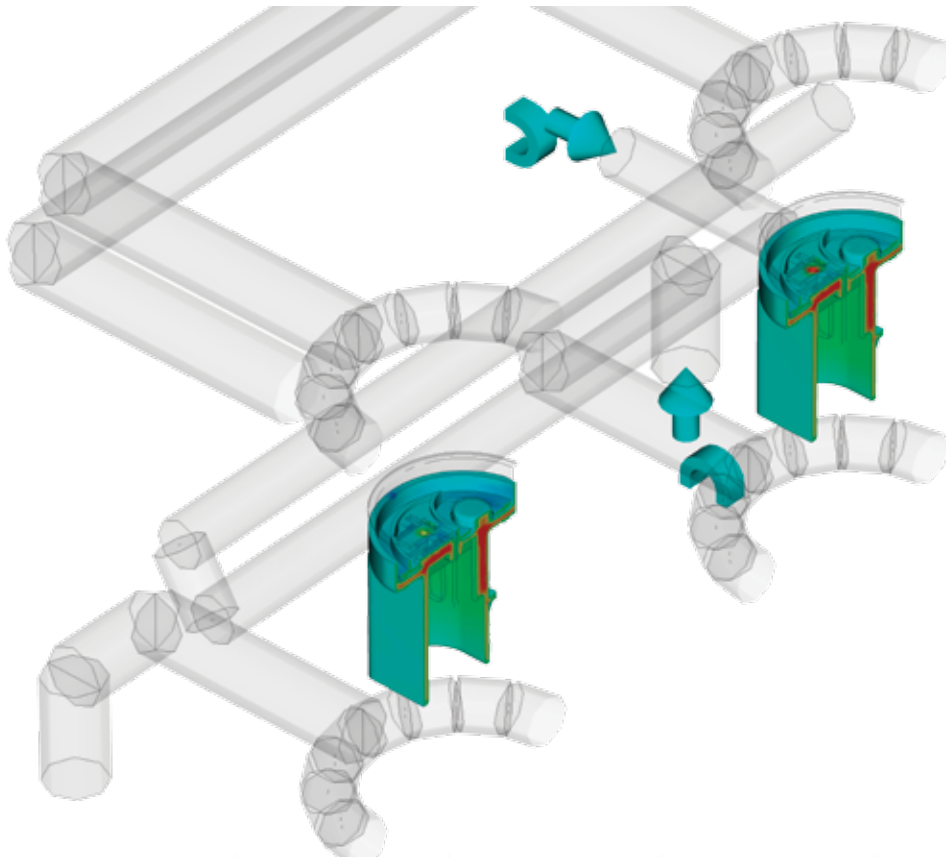

Simulation

Thermoset Flow Simulation

Simulate thermoset injection molding, RIM/SRIM, resin transfer molding, and rubber compound injection molding.

Reactive Injection Molding

Predict how molds will fill with or without fiber-reinforced pre-forms. Help avoid short shots due to pre-gelation of resin, and identify air traps and problematic weld lines. Balance runner systems, select molding machine size, and evaluate thermoset materials.

Microchip Encapsulation

Simulate encapsulation of semiconductor chips with reactive resins and the interconnectivity of electrical chips. Predict bonding wire deformation within the cavity and shifting of the lead frame due to pressure imbalances.

Underfill Encapsulation

Simulate flip-chip encapsulation to predict material flow in the cavity between the chip and the substrate.

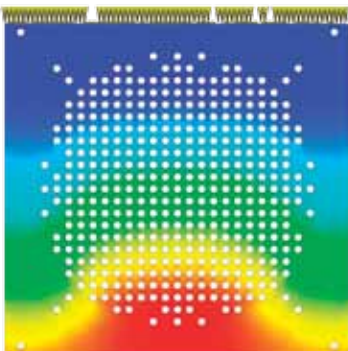

Leading-Edge Simulation Tools

Use leading-edge simulation tools to solve design challenges.

Insert Overmolding

Run an insert overmolding simulation to help determine the impact of mold inserts on melt flow, cooling rate, and part warpage.

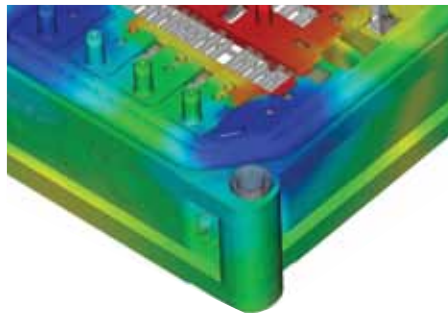

Two-Shot Sequential Overmolding

Simulate the two-shot sequential overmolding process: one part is filled; the tool opens and indexes to a new position; and a second part is molded over the first.

Birefringence

Predict optical performance of an injection-molded part by evaluating refractive index changes that result from process-induced stresses. Evaluate multiple materials, processing conditions, and gate and runner designs to help control birefringence in the part.

Specialized Molding Processes

Simulate a wide range of plastic molding processes and state-of-the-art process applications.

Gas-Assisted Injection Molding

Determine where to position polymer and gas entrances, how much plastic to inject prior to gas injection, and how to optimize size and placement of gas channels.

Co-Injection Molding

Visualize the advancement of skin and core materials in the cavity and view the dynamic relationship between the two materials as filling progresses. Optimize material combinations while maximizing the product's cost-performance ratio.

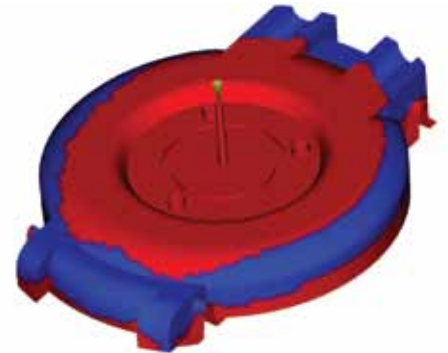

Injection-Compression Molding

Simulate simultaneous or sequential polymer injection and mold compression. Evaluate material candidates, part and mold design, and processing conditions.

CAD Interoperability and Meshing

Use tools for native CAD model translation and optimization. Get geometry support for thin-walled parts and thick and solid applications. Select mesh type based on desired simulation accuracy and solution time.

CAD Solid Models

Import and mesh solid geometry from Parasolid®-based CAD systems, Autodesk® Inventor® software, CATIA® V5, Pro/ENGINEER®, and SolidWorks®, as well as IGES and STEP universal files.

Error Checking and Repair

Scan imported geometry and automatically fix defects that can occur when translating the model from CAD software.

Centerline Import/Export

Import and export feed system and cooling channel centerlines from and to CAD software to help decrease modeling time and avoid runner and cooling channel modeling errors.

Autodesk® Moldflow® CAD Doctor

Check, correct, heal, and simplify solid models imported from 3D CAD systems to prepare for simulation.

3D Simulations

Perform 3D simulations on complex geometry using a solid, tetrahedral, finite element mesh technique. Ideal for electrical connectors, thick structural components, and geometries with thickness variations.

Dual Domain Technology

Simulate solid models of thin-walled parts using Dual Domain™ technology. Work directly from 3D solid CAD models, leading to easier analysis of design iterations.

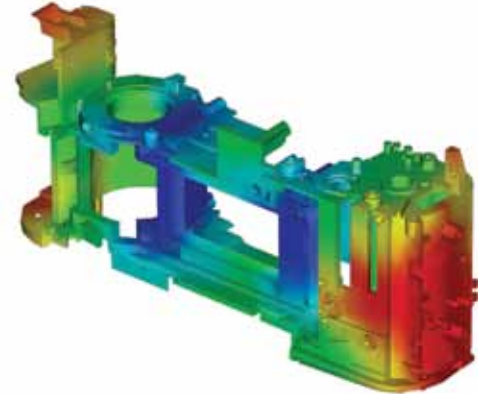
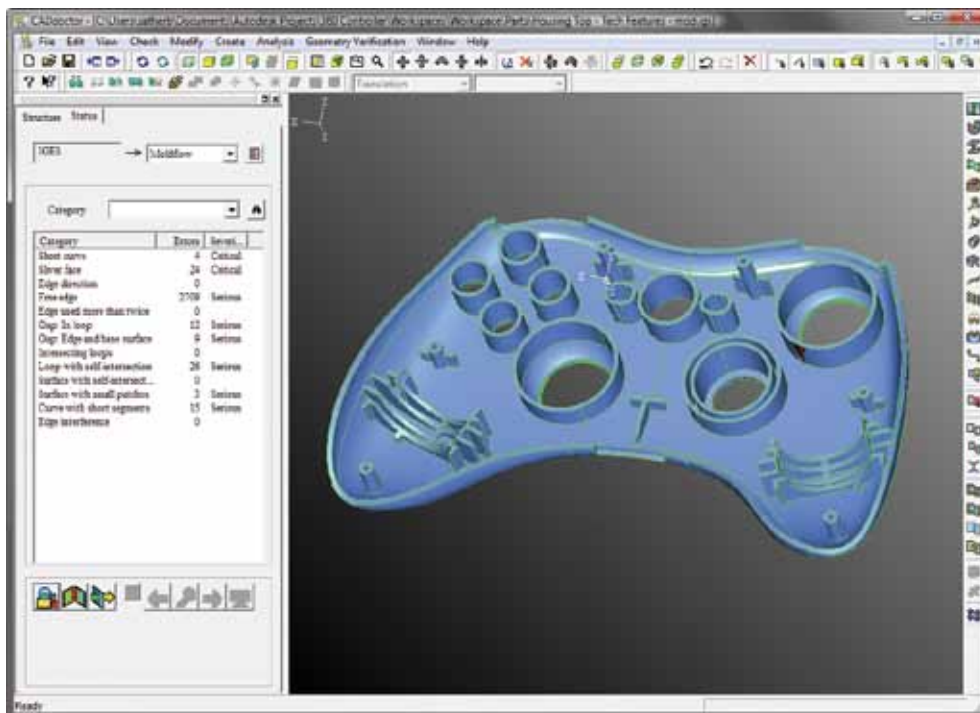

Midplane Meshes

Generate 2D planar surface meshes with assigned thicknesses for thin-walled parts.

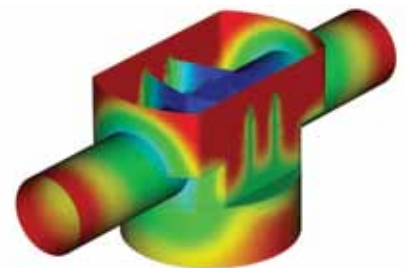

Results Evaluation and Productivity Tools

Visualize and evaluate simulation results, and use the automatic reporting tools to share the results with stakeholders. Take advantage of features such as a materials database and customizable workspaces to further boost productivity.

Results Interpretation & Presentation

Use a wide range of tools for model visualization, results evaluation, and presentation.

Automatic Reporting Tools

Use the Report Generation Wizard to create web-based reports. Prepare and share simulation results more quickly and easily with customers, vendors, and team members.

Microsoft® Office

Export results and images for use in Microsoft® Word reports and PowerPoint® presentations.

Autodesk® Moldflow® Communicator

Collaborate with manufacturing personnel, procurement engineers, suppliers, and external customers using Autodesk® Moldflow® Communicator software. The Autodesk Moldflow Communicator results viewer enables you to export results from Autodesk Moldflow software so stakeholders can more easily visualize, quantify, and compare simulation results.

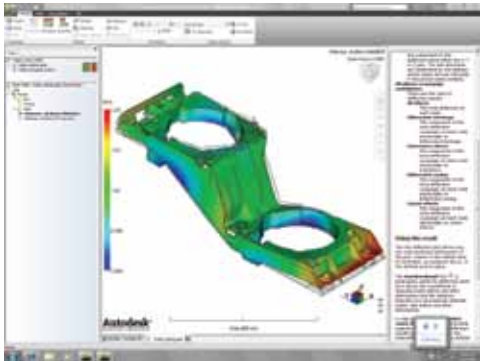

Material Data

Improve simulation accuracy with precise material data.

Materials Database

Use the built-in materials database of grade-specific information on more than 8,000 plastic materials characterized for use in plastic injection molding simulation.



Autodesk® Moldflow® Plastics Labs

Get state-of-the-art plastic material testing services, expert data-fitting services, and extensive material databases.

Productivity Tools

Use extensive help to boost productivity.

Help

Get help on a results plot, including information on what to look for and how to correct typical problems. Learn more about solver theory, interpreting simulation results, and designing better plastic parts and injection molds.

Automation and Customization

Automate common tasks and customize Autodesk Moldflow software for your organization.

API Tools

Application programming interface (API) tools expand the functionality of Autodesk Moldflow software by enabling you to automate common tasks, customize the user interface, work with third-party applications, and help implement corporate standards and best practices.

Workspaces

Customize the user interface and application features for your team. Set up profiles to guide new users through the simulation process and identify common problems. Define other profiles to give additional functionality and flexibility to more experienced users.

